

DRAINMINOR 30 SL (240V)
(Wastewater Pumping System)



DrainMinor 30 SL Part No 113
(Wastewater Pumping System. Ideal for wastewater containing mildly corrosive chemicals. 20 parts per million concentration)

General Description:

DrainMinor 30 SL features a heavy-duty tank and submersible pump for automatically pumping wastewater. This small pump features a shaft mechanical seal rather than lip seals, therefore it is suitable for applications like - Laboratories, vets, dentists, hairdresser, janitor sinks and coffee shops where excess coffee granules and milk skin is being washed down a sink.

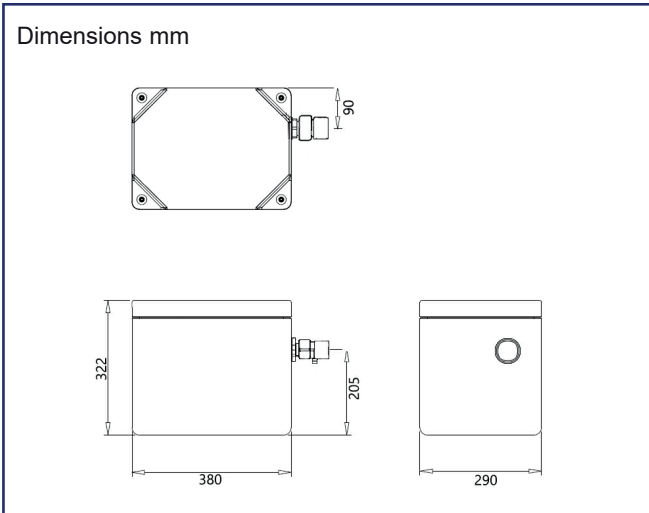

Tank:

Manufactured from recyclable polyethylene and fully rigged with internal pipe work and non-return valve. The lid is held in place with easy-to-remove hand screws and sits on a custom moulded, fitted rubber seal.

Tank Inlets:

To suit site layout, all inverts should be brought into the side of the tank by drilling a hole and using an appropriate tank connector. Minimum invert height 110 mm.

Tank Outlet:

Fitted 1¼" BSP male thread discharge outlet (NRV supplied female thread)

Tank Venting:

The tank is fitted with its own vent.

Good for the Environment:



DrainMinor tanks are made from Recyclable Polyethylene.

Recycling polyethylene is highly cost effective and therefore successful. It is greener than incineration, far more eco-friendly than landfill disposal and easier to use when manufacturing products such as toys, recycling bins, envelopes and much more.

Pump:

- For saline solutions up to 15 % salinity
- Cooling jacket for motor housing
- Low level pumping by detachable strainer base
- Flushing device activatable and deactivatable
- Variable discharge branch with closable ventilation
- Run dry protection
- EIP Technology
- SiC mechanical seal
- Moisture sealed cable inlet



Description:

The heavy duty centrifugal submersible drainage pump U3K SPEZIAL is suitable for dealing with wastewater and capable of handling soft solids up to 10mm in particle size.

The U3K SPEZIAL is a variant of the U3k (with Mechanical shaft seal) and designed to pump wastewater containing mildly corrosive chemicals (20 parts per million concentration)

Dimensions/switching points U3 KS (mm)

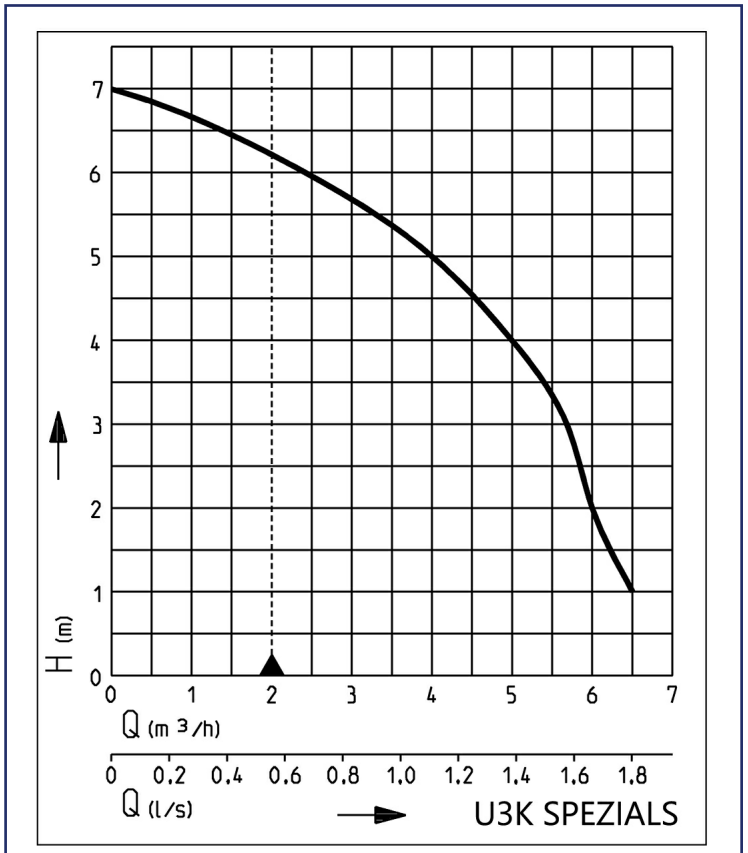
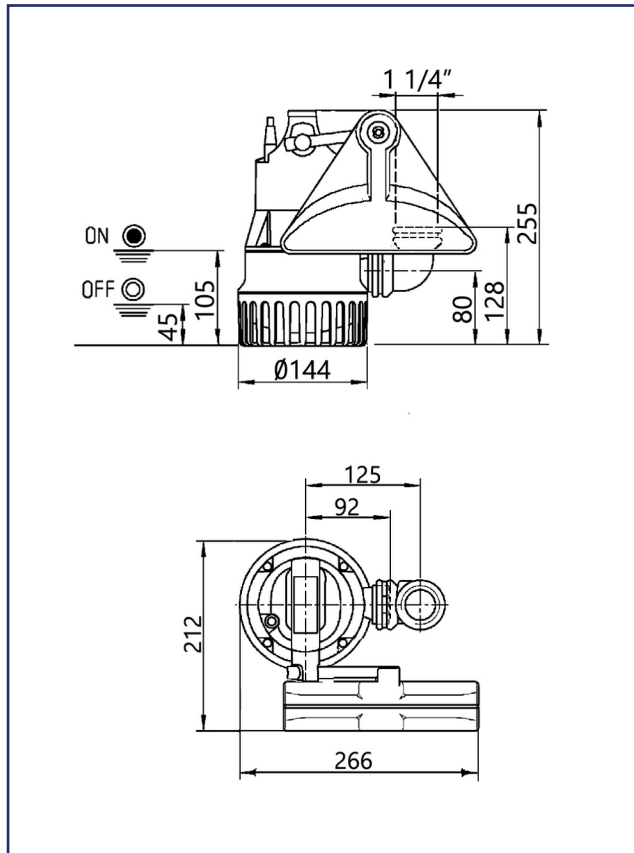

Scope of Supply

Pump ready for connection acc. to EN 12050 with 90°, 1¼" female connection elbow, 4m cable with automatic level float switch.

Mechanical Data

Pump	Vertical single stage	Run dry protection	Yes
Free Passage	10 mm	Shaft	Stainless Steel
Bearing	Ball bearing, grease-lubricated	Impeller	Vortex impeller, GFK
Seal on motor side	Rotary shaft seal	Motor housing	Stainless Steel
Oil chamber	Yes	Pump housing	GRP
Seal on medium side	SiC mechanical seal	Submersible	Yes
		Pressure outlet	1¼"

Electrical Data

Voltage	1/N/PE-230V	Type of enclosure	IP 68
Motor rating P1	0.32kW	Insulation class	B
Motor rating P2	0.2kW	Winding thermostat	Yes
Current	1.4A	Motor protection	Integrated
Type of enclosure	3G1,0	Plug	Safety

U3 SPEZIAL

Type	Code No.	Power line	Weight
With built-in level control			
U3 KS spezial, 4m cable	JP50005	4m H07RN-F	3.7kg

Notes:

- This unit is for wastewater only
- Ensure the location of the DrainMinor enables the lid to be easily removed for regular inspection and maintenance
- If the discharge pipework connection to a soil stack, manhole etc. is below the discharge outlet of the tank, an anti-syphon unit must be fitted at the highest point of the discharge pipework
- Warranty: The DrainMinor 30 SL (240V) comes complete with a one year warranty.

Pump Technology Ltd. - 0118 9821 555 - www.pumptechnology.co.uk

Official Distributor and Stockist Authorised by Jung Pumpen GmbH



3 of 3

Pump Technology Ltd. reserves the right to change the specification without prior notice.