

**GreaseGulper Large - Part No. GGL****Application:** Medium Restaurants / Hotels**General Description:**

This UK built grease trap, manufactured from rust free 304 Stainless Steel, has a 60 litre capacity and is designed for under sink, workbench or external installation.

It is adequate for most small takeaways, cafes restaurants etc. with 1-3 small commercial sinks and dishwasher and features an air tight Neoprene seal to lock in odours.

**Complies with:** BS EN 1825-1:2004 UK Building Regulations**Designed in accordance with:** BS EN 1825-2:2002

- All Fittings supplied
- Removable Filter Basket
- Adjustable, levelling feet
- Rust Free Stainless Steel
- Air tight Neoprene lid seal
- Simple to Install

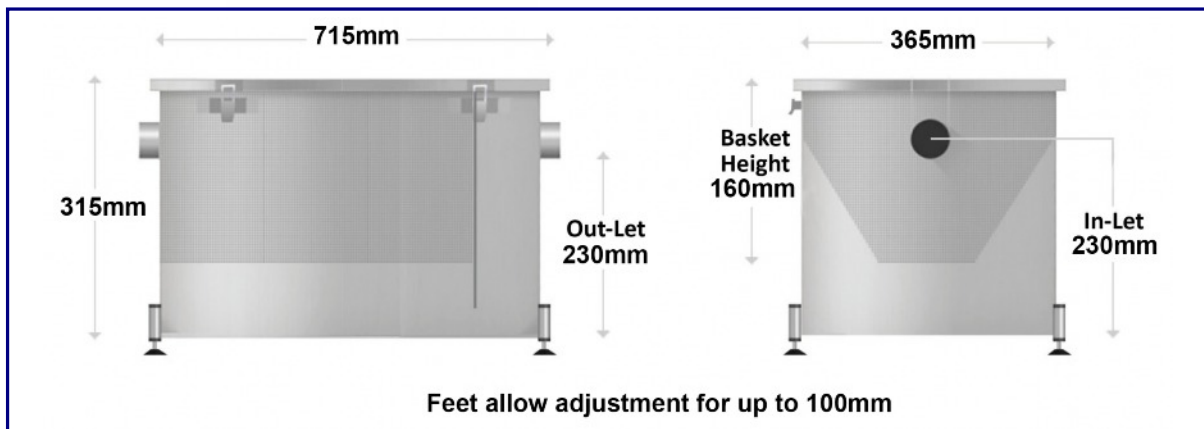

Capacity:	60 Litres
Application:	Medium Restaurants / Hotels
Product Use:	1-3 Medium Commercial Sinks & Dishwasher
Inlet:	40 mm
Outlet:	50 mm
Seal:	Neoprene
Material:	304 Grade Stainless Steel Heavy Duty
Installation:	Under Sink / Work Bench or External
Dry Weight:	18 kg

The hugely popular Filtra-Trap® is a high quality, heavy-duty, Stainless-Steel filtration mesh grease trap, which is very easy to clean & maintain.

It not only traps all fats, oils and greases, but it's large fine mesh filter will also filter out virtually all solids, the other main cause of blockages, leaving drains Free & Clear.