

DRAINMAJOR DUO 1030 (240V) (Duty/Standby Wastewater Pumping System with Dual Alarm)



DrainMajor Duo 1030 (240V) Part No. 145
(Duty/Standby Wastewater Pumping System with
Dual Alarm)

General Description:

DrainMajor Duo 1030 (240V) features a heavy-duty tank and submersible pump for automatically pumping wastewater from commercial kitchens, teapoints, etc.

The DrainMajor Duo provides users with the additional security of duty/standby operation. If one pump should become blocked or fail, the wastewater would rise within the tank, activate the high-level alarm, overflow into the adjoining tank where the other pump would then act as the standby pump.



Alarm:

The dual zone alarm has two triggered inputs. When triggered it is activated and an LED indication of which input was triggered is illuminated.

It has a built-in backup battery (72 hours) in the event of a power outage. It operates from a switched input, such as a float switch or pressure switch. The alarm can be activated either by a closed circuit switched input or an open circuit switched input. It is designed for connection to 240Vac supply voltages. Once activated, it provides a visual and audio indicator.

There is an option to connect an external beacon or other circuitry via the auxiliary output and/or the volt-free relay outputs. Each trigger has its own volt-free relay allowing the alarm to be connected to a Building Management System with ease.

Key Alarm Features

- 2 Alarm inputs
- Alarm LED indicator
- Alarm audio buzzer
- Alarm audio mute button
- Alarm test button
- Power LED indicator
- IP65-rated enclosure
- Auxiliary alarm output for accessories such as a beacon or siren
- 2 independent Volt free relay contact outputs SPDT
- Easy installation no tool required WAGO wiring terminals
- Backup battery with up to 72 hours of run time

Pump Technology Ltd. - 0118 9821 555 - www.pumptechnology.co.uk

**DRAINMAJOR DUO 1030 (240V)
(Duty/Standby Wastewater Pumping
System with Dual Alarm)**

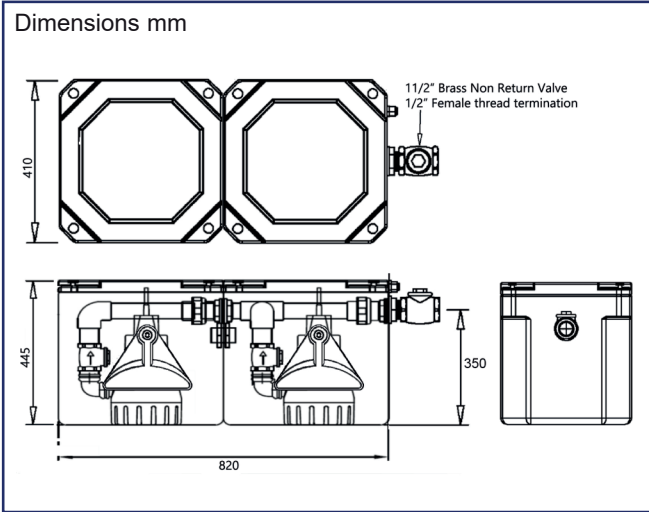

Tank:

Manufactured from recyclable polyethylene and fully rigged with internal pipe work and non-return valve. The lid is held in place with easy-to-remove hand screws and sits on a custom moulded, fitted rubber seal.

Tank Volume: 149.6 litres

Total Approximate Usable Volume - 99.6 litres

Tank Inlets:

To suit site layout, all inverts should be brought into the side of the tank by drilling a hole and using an appropriate tank connector. Minimum invert height 185 mm.

Tank Outlet:

Fitted 1 1/2" BSP male thread discharge outlet (NRV supplied female thread)

Tank Venting:

To suit site layout, a vent should be taken from the side of the tank by drilling a hole and using an appropriate tank connector. Vent pipe should be 1 1/4" min. to air or via a Pump Technology MicroVent.

It is essential to have inlets into both tanks to ensure both pumps operate.

Good for the Environment:



DrainMajor Duo tanks are made from Recyclable Polyethylene.

Recycling polyethylene is highly cost effective and therefore successful. It is greener than incineration, far more eco-friendly than landfill disposal and easier to use when manufacturing products such as toys, recycling bins, envelopes and much more.

**DRAINMAJOR DUO 1030 (240V)
(Duty/Standby Wastewater Pumping
System with Dual Alarm)**

Pump:

- Safe to run dry
- 30 mm free passage
- Controllable oil chamber
- SiC mechanical seal independent of sense of rotation
- Replaceable moisture sealed cable inlet
- Fluid temperature 35°C, temporarily 60°C (10 mins)

Description:

The heavy duty centrifugal submersible drainage pump US 103 ES is suitable for dealing with wastewater and capable of handling soft solids up to 30 mm particle size.



Dimensions/switching points US 103 ES (mm)

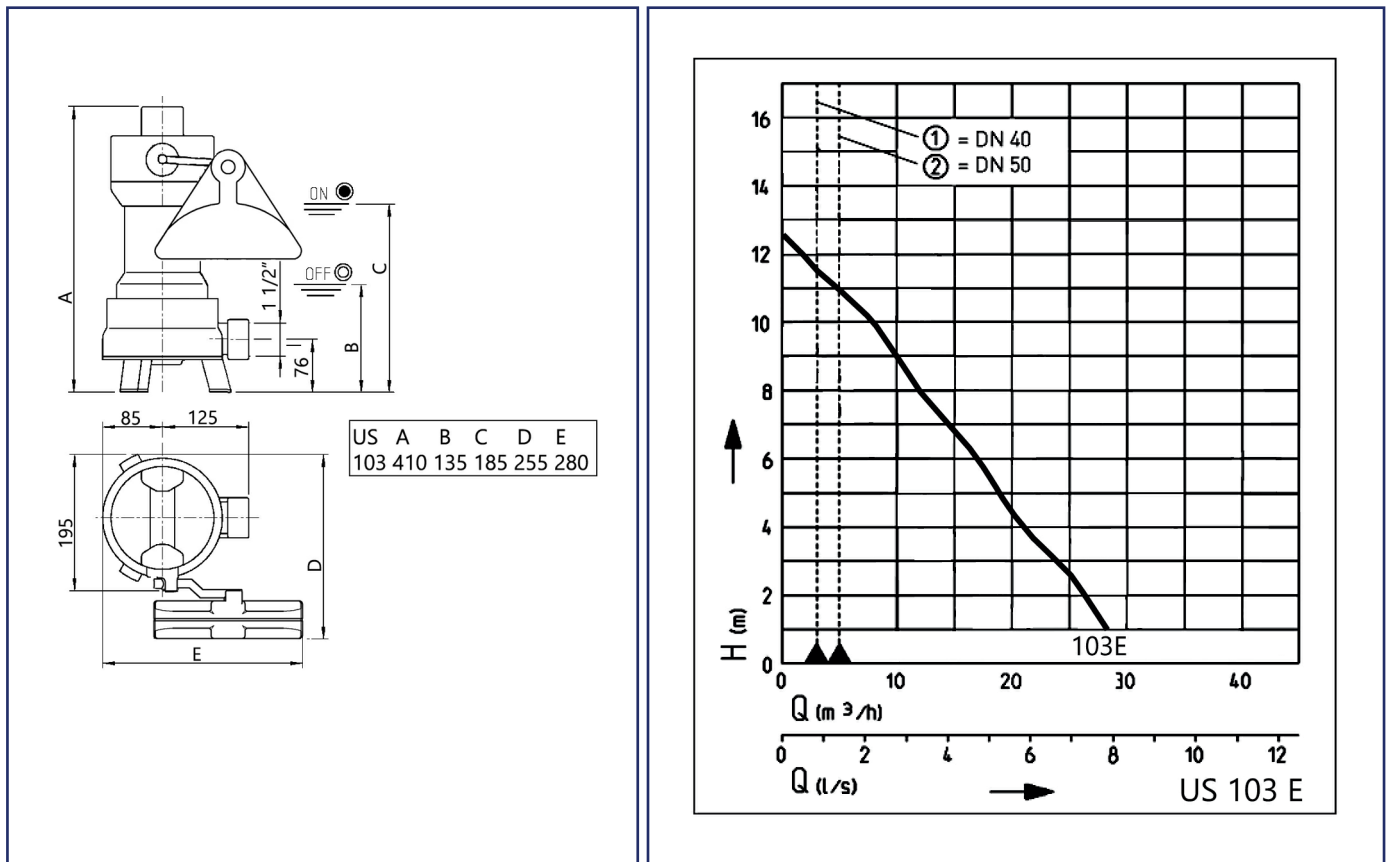

Scope of Supply

Pump according to DIN EN 12050 ready for connection with 4m cable and automatic level float switch.

Mechanical Data			
Pump	Vertical single stage	Shaft	Stainless Steel
Bearing	Ball bearing, grease-lubricated	Impeller	Vortex impeller, GFK
Seal on motor side	Duplex rotary shaft seals	Motor Housing	Edelstahl (253: Grauguss)
Oil chamber	Yes	Pump Housing	Grey cast iron
Seal on medium side	SiC Mechanical seal	Submersible	Yes
Run dry protection	Yes	Pressure outlet	IG 1½" (US253:2")

Electrical Data			
Power line	10m H07RN-F	Insulation class	B (253:F)
Type of enclosure	IP68	Winding thermostat	Yes

US 103 ES

Type	Code No.	Voltage	Motor rating P1	Motor rating P2	Current	Wires	Motor protection	Plug	Free passage	Weight
With built-in level control										
US 103 ES	JP09281	1/N/PE-230V	1.37kW	0.98kW	6.0A	3G1,0	Integrated	Safety	30 mm	14.0kg

Notes:

- This unit is for wastewater only
- Ensure the location of the DrainMajor enables the lid to be easily removed for regular inspection and maintenance
- If the discharge pipework connection to a soil stack, manhole etc. is below the discharge outlet of the tank, an anti-syphon unit must be fitted at the highest point of the discharge pipework
- Warranty: The DrainMajor Duo 1030 (240V) comes complete with a one year warranty.

Pump Technology Ltd. - 0118 9821 555 - www.pumptechnology.co.uk

Official Distributor and Stockist Authorised by Jung Pumpen GmbH



4 of 4

Pump Technology Ltd. reserves the right to change the specification without prior notice.