

DRAINMAJOR DUO 30 SL (240V) (Duty/Standby Wastewater Pumping System with Dual Alarm)



DrainMajor Duo 30 SL Part No 157/A
(Wastewater Pumping System. Ideal for
wastewater containing mildly corrosive chemicals.
20 parts per million concentration)

General Description:

DrainMajor Duo 30 SL features a heavy-duty tank and submersible pump for automatically pumping wastewater. This small pump features a shaft mechanical seal rather than lip seals, therefore it is suitable for applications like - Laboratories, vets, dentists, hairdresser, janitor sinks and coffee shops where excess coffee granules and milk skin is being washed down a sink.



The DrainMajor Duo provides users with the additional security of duty/standby operation. If one pump should become blocked or fail, the wastewater would rise within the tank, activate the high-level alarm, overflow into the adjoining tank were the other pump would then act as the standby pump.

Alarm:

The dual zone alarm has two triggered inputs. When triggered it is activated and an LED indication of which input was triggered is illuminated.

It has a built-in backup battery (72 hours) in the event of a power outage. It operates from a switched input, such as a float switch or pressure switch. The alarm can be activated either by a closed circuit switched input or an open circuit switched input. It is designed for connection to 240Vac supply voltages. Once activated, it provides a visual and audio indicator.

There is an option to connect an external beacon or other circuitry via the auxiliary output and/or the volt-free relay outputs. Each trigger has its own volt-free relay allowing the alarm to be connected to a Building Management System with ease.

Key Alarm Features

- 2 Alarm inputs
- Alarm LED indicator
- Alarm audio buzzer
- Alarm audio mute button
- Alarm test button
- Power LED indicator
- IP65-rated enclosure
- Auxiliary alarm output for accessories such as a beacon or siren
- 2 independent Volt free relay contact outputs SPDT
- Easy installation no tool required WAGO wiring terminals
- Backup battery with up to 72 hours of run time

Pump Technology Ltd. - 0118 9821 555 - www.pumptechnology.co.uk

DRAINMAJOR DUO 30 SL (240V) (Duty/Standby Wastewater Pumping System with Dual Alarm)

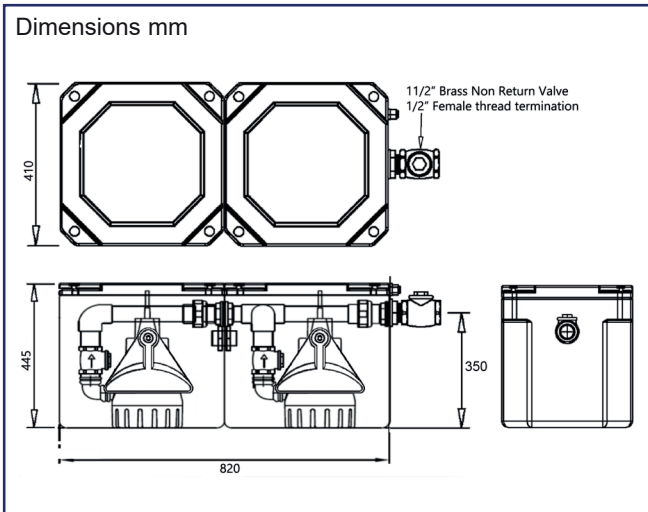

Tank:

Manufactured from recyclable polyethylene and fully rigged with internal pipe work and non-return valve. The lid is held in place with easy-to-remove hand screws and sits on a custom moulded, fitted rubber seal.

Tank Volume: 149.6 litres

Total Approximate Usable Volume - 99.6 litres

Tank Inlets:

To suit site layout, all inverts should be brought into the side of the tank by drilling a hole and using an appropriate tank connector. Minimum invert height 110 mm.

Tank Outlet:

Fitted 1½" BSP male thread discharge outlet (NRV supplied female thread)

Tank Venting:

To suit site layout, a vent should be taken from the side of the tank by drilling a hole and using an appropriate tank connector. Vent pipe should be 1¼" min. to air or via a Pump Technology MicroVent.

It is essential to have inlets into both tanks to ensure both pumps operate.

Good for the Environment:



DrainMajor Duo tanks are made from Recyclable Polyethylene.

Recycling polyethylene is highly cost effective and therefore successful. It is greener than incineration, far more eco-friendly than landfill disposal and easier to use when manufacturing products such as toys, recycling bins, envelopes and much more.

**DRAINMAJOR DUO 30 SL (240V)
(Duty/Standby Wastewater Pumping
System with Dual Alarm)**

Pump:

- For saline solutions up to 15% salinity
- SiC mechanical seal
- Cooling jacket for motor housing
- Flushing device activatable and deactivatable
- Variable discharge branch with closable ventilation
- Run dry protection
- EIP Technology
- Moisture sealed cable inlet
- Fluid temperature 35°C, temporarily 60°C (10 mins)



Description:

The heavy duty centrifugal submersible drainage pump U3K SPEZIAL is suitable for dealing with wastewater and capable of handling soft solids up to 10mm in particle size.

The U3K SPEZIAL is a variant of the U3K (with Mechanical shaft seal) and designed to pump wastewater containing mildly corrosive chemicals, 20 parts per million concentration.

Dimensions/switching points U3 KS (mm)

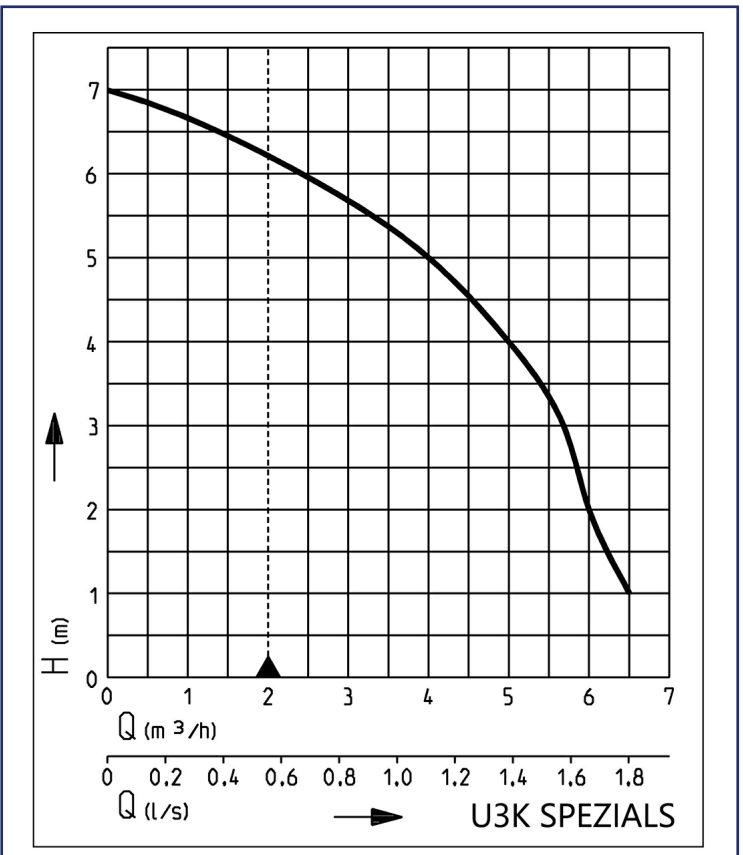
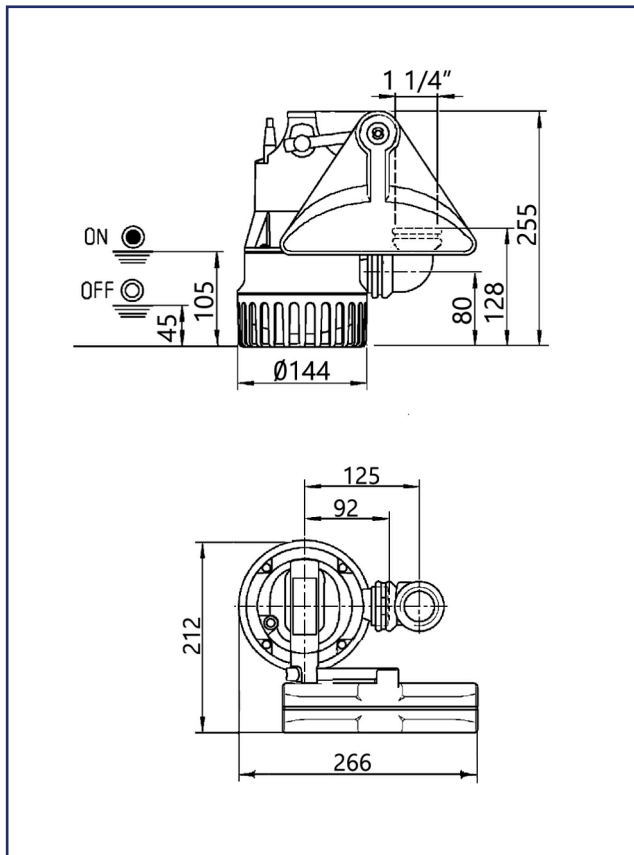

DRAINMAJOR DUO 30 SL (240V) (Duty/Standby Wastewater Pumping System with Dual Alarm)

Scope of Supply

Pump ready for connection acc. to EN 12050 with 90°, 1¼" female connection elbow, 4m cable and automatic level float switch.

Mechanical Data			
Pump	Vertical single stage	Run dry protection	Yes
Free Passage	10 mm	Shaft	Stainless Steel
Bearing	Ball bearing, grease-lubricated	Impeller	Vortex impeller, GFK
Seal on motor side	Rotary shaft seal	Motor housing	Stainless Steel
Oil chamber	Yes	Pump housing	GRP
Seal on medium side	SiC mechanical seal	Submersible	Yes
		Pressure outlet	1¼"
Electrical Data			
Voltage	1/N/PE-230V	Type of enclosure	IP 68
Motor rating P1	0.32kW	Insulation class	B
Motor rating P2	0.2kW	Winding thermostat	Yes
Current	1.4A	Motor protection	Integrated
Type of enclosure	3G1,0	Plug	Safety

U3 SPEZIAL

Type	Code No.	Power line	Weight
With built-in level control			
U3 KS spezial, 4m cable	JP50005	4m H07RN-F	3.7kg

Notes:

- This unit is for wastewater only
- Ensure the location of the DrainMajor enables the lid to be easily removed for regular inspection and maintenance
- If the discharge pipework connection to a soil stack, manhole etc. is below the discharge outlet of the tank, an anti-syphon unit must be fitted at the highest point of the discharge pipework
- Warranty: The DrainMajor 30 SL (240V) comes complete with a one year warranty.

Pump Technology Ltd. - 0118 9821 555 - www.pumptechnology.co.uk

Official Distributor and Stockist Authorised by Jung Pumpen GmbH



4 of 4

Pump Technology Ltd. reserves the right to change the specification without prior notice.