

DRAINMAJOR DUO 730 HES (240V) (Duty/Standby Hot Wastewater Pumping System with Dual Alarm)



DrainMajor Duo 730 HES (240V) Part No. 143
(Duty/Standby Hot Wastewater Pumping System
with Dual Alarm. Continuously rated for 90°C Hot
Wastewater)

General Description:

DrainMajor Duo 730 HES (240V) features a heavy-duty tank and submersible pump for automatically pumping “Hot Wastewater” from tea points with zip taps, commercial kitchens, sinks, dishwashers, combi ovens, pasta cookers, washing machines etc.

The DrainMajor Duo provides users with the additional security of duty/standby operation. If one pump should become blocked or fail, the wastewater would rise within the tank, activate the high-level alarm, overflow into the adjoining tank were the other pump would then act as the standby pump.

Alarm:

The dual zone alarm has two triggered inputs. When triggered it is activated and an LED indication of which input was triggered is illuminated.

It has a built-in backup battery (72 hours) in the event of a power outage. It operates from a switched input, such as a float switch or pressure switch. The alarm can be activated either by a closed circuit switched input or an open circuit switched input. It is designed for connection to 240Vac supply voltages. Once activated, it provides a visual and audio indicator. There is an option to connect an external beacon or other circuitry via the auxiliary output and/or the volt-free relay outputs. Each trigger has its own volt-free relay allowing the alarm to be connected to a Building Management System with ease.



Key Alarm Features

- 2 Alarm inputs
- Alarm LED indicator
- Alarm audio buzzer
- Alarm audio mute button
- Alarm test button
- Power LED indicator
- IP65-rated enclosure
- Auxiliary alarm output for accessories such as a beacon or siren
- 2 independent Volt free relay contact outputs SPDT
- Easy installation no tool required WAGO wiring terminals
- Backup battery with up to 72 hours of run time

Pump Technology Ltd. - 0118 9821 555 - www.pumptechnology.co.uk

**DRAINMAJOR DUO 730 HES (240V)
(Duty/Standby Hot Wastewater
Pumping System with Dual Alarm)**

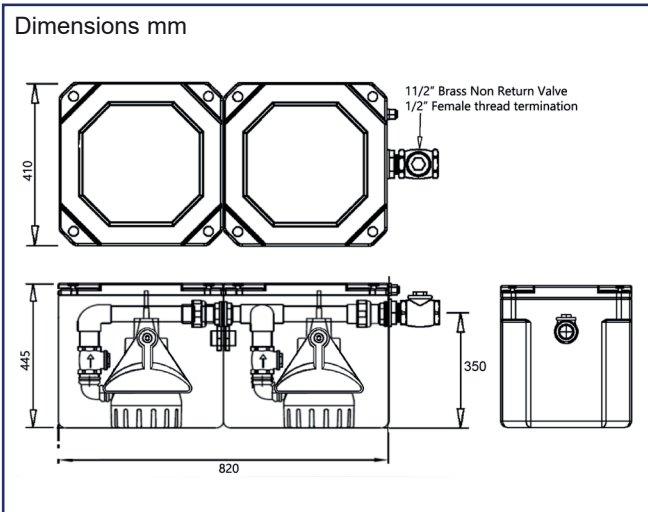

Tank:

Manufactured from recyclable polyethylene and fully rigged with internal pipe work and non-return valve. The lid is held in place with easy-to-remove hand screws and sits on a custom moulded, fitted rubber seal.

Tank Volume: 149.6 litres

Total Approximate Usable Volume - 99.6 litres

Tank Inlets:

To suit site layout, all inverts should be brought into the side of the tank by drilling a hole and using an appropriate tank connector. Minimum invert height 155 mm.

Tank Outlet:

Fitted 1 1/2" BSP male thread discharge outlet (NRV supplied female thread)

Tank Venting:

To suit site layout, a vent should be taken from the side of the tank by drilling a hole and using an appropriate tank connector. Vent pipe should be 2" to air or via a Pump Technology MicroVent.

It is essential to have inlets into both tanks to ensure both pumps operate.

Good for the Environment:



DrainMajor Duo tanks are made from Recyclable Polyethylene.

Recycling polyethylene is highly cost effective and therefore successful. It is greener than incineration, far more eco-friendly than landfill disposal and easier to use when manufacturing products such as toys, recycling bins, envelopes and much more.

Pump:

- Safe to run dry
- 30 mm free passage
- Hot water up to 90°C (Rated for continuous operation)
- Controllable oil chamber
- SiC mechanical seal independent of sense of rotation
- Replaceable moisture sealed cable inlet

Description:

The heavy duty centrifugal submersible drainage pump US 73 HES is suitable for dealing with wastewater and capable of handling soft solids up to 30mm in particle size.

The Pump is rated for continuous operation for very hot wastewater up to 90°C.



Dimensions/switching points US 73 HES (mm)

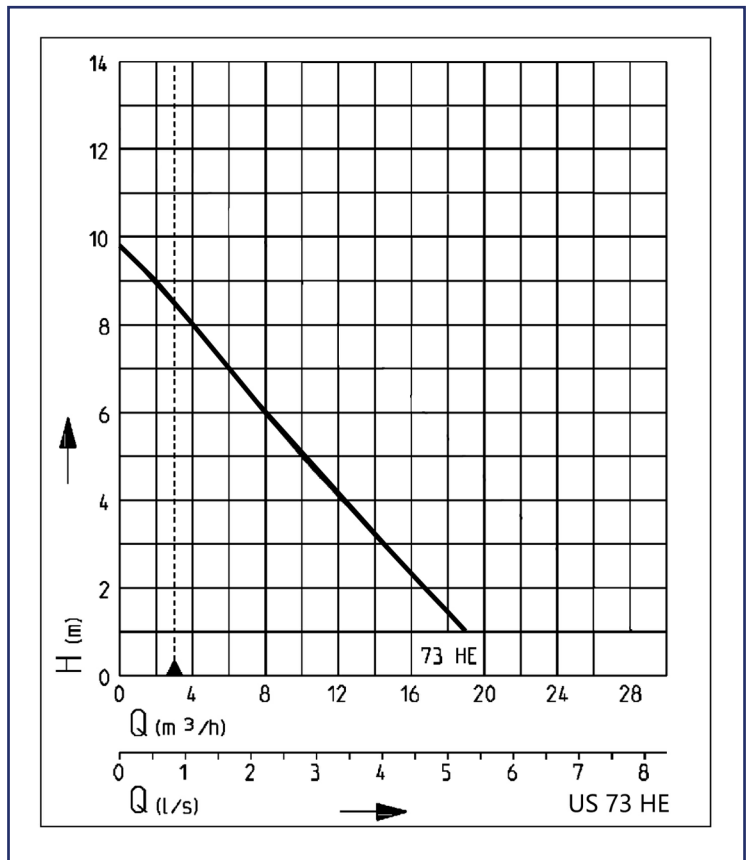
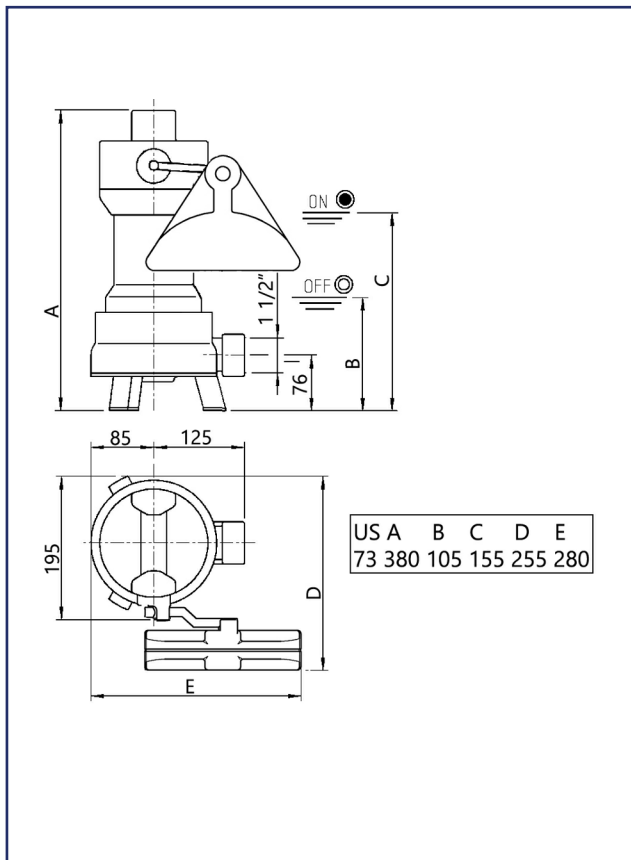

Scope of Supply

Pump acc. To EN 12050 ready for connection with 4m cable and automatic level float control.

Mechanical Data			
Pump	Vertical single stage	Run dry protection	Yes
Free passage	30mm	Shaft	Stainless Steel
Bearing	Ball bearing, grease-lubricated	Impeller	Vortex impeller GFK
Seal on motor side	Duplex rotary shaft seals	Motor housing	Stainless Steel
Oil chamber	Yes	Pump housing	Grey cast iron
Seal on medium side	SiC Mechanical seal	Submersible	Yes
		Pressure outlet	IG 1½"

Electrical Data			
Voltage	1/N/PE-230V	Insulation class	F
Power line	10m H07RN-F	Winding thermostat	Yes
Wires	3G1.0	Motor protection	Integrated
Type of enclosure	IP68	Plug	Safety

US 73 HES

Type	Code No.	Motor rating P1	Motor rating P2	Current	Weight
US 73 HES	JP09264	0.83kW	0.50kW	3.9A	12.5kg

Notes:

- This unit is for wastewater only
- Ensure the location of the DrainMajor enables the lid to be easily removed for regular inspection and maintenance
- If the discharge pipework connection to a soil stack, manhole etc. is below the discharge outlet of the tank, an anti-syphon unit must be fitted at the highest point of the discharge pipework
- Warranty: The DrainMajor Duo 730 HES (240V) comes complete with a one year warranty.

Pump Technology Ltd. - 0118 9821 555 - www.pumptechnology.co.uk

Official Distributor and Stockist Authorised by Jung Pumpen GmbH



4 of 4

Pump Technology Ltd. reserves the right to change the specification without prior notice.