



## **Installation, Operation and Maintenance Manual. DrainMinor Range**

DrainMinor 30 (240V) Part No 111	SECTION 1
DrainMinor 30 SL (240V) Part No 113	SECTION 2
DrainMinor C (240 V) (Combi Oven Pump) Part No 113C	SECTION 3
DrainMinor S (240V)(Shower Pump) Part No 113S	SECTION 4

Pump Technology Ltd. Unit 56, Youngs Industrial Estate, Aldermaston, Berks RG7 4PW

**Telephone: 0118 982 1555**

Email: [support@pumptechnology.co.uk](mailto:support@pumptechnology.co.uk) - Web: [www.pumptechnology.co.uk](http://www.pumptechnology.co.uk)

### **INSTALLATION GUIDELINES:**

The DrainMinor should be positioned on a firm level surface. The unit must be located lower than the outflow of the appliances served so as to provide a gravity fall into the unit. It is extremely important to site the DrainMinor with access in mind in the event of maintenance being required.

### **ON DELIVERY:**

Remove lid, check pump is correctly positioned and connecting pipework has not been damaged in transit.

### **INLET CONNECTIONS:**

Inlets can be positioned on the DrainMinor to suit your site requirements. All inverts should be brought into the tank (using tank connectors) at the highest possible level from the floor. See technical info on each product for minimum invert level. Ensure that the inflow of water is not directed onto the float mechanism.

### **NOTE:**

No connections to be put through the lid as this inhibits easy removal of the lid for cleaning tank. (Note: tank MUST be positioned in such a way that lid can be removed easily to allow access to tank interior and pump cleaning)

### **DISCHARGE CONNECTION:**

The tank has a 1.1/4" BSP male thread discharge outlet. (NRV supplied is female thread). Plastic non-return valve supplied in the horizontal position, we recommend that this is fitted in the vertical position on the first lift. All pipework must be run in UPVC solvent weld.

### **IMPORTANT:**

Any bends in the rising main must be slow radius swept 90's. If the discharge pipework connects to a soil stack, manhole, etc. below the discharge outlet of the tank, an anti-syphon valve must be fitted to the highest point of the discharge pipework.

### **ELECTRICAL CONNECTION:**

A qualified person in accordance with the Institute Of Electrical Engineers Regulations should connect the unit to the appropriate mains supply taking into account all the electrical information provided.

### ***ELECTRICAL CONNECTION CONTINUED:***

***Power supply to Pump and Alarm must be via independent fused spurs. An isolator switch to the power supply must also be installed.***

### **IMPORTANT:**

All pump systems must be used with an appropriate motor rated protection device. VENTING Unit is complete with an integrated carbon vent.

### **MAINTENANCE:**

Before any inspection or maintenance please ensure the power supply is turned off. The collecting tank should be inspected at least every 4 weeks. All debris, fats and grease should be removed.

Maintenance every 6 to 12 months depending upon the nature of the application is recommended.

For scheduled inspection / cleaning and maintenance please call Pump Technology Services Ltd. (Direct Line)

**Tel 0118 3385 724**

Email

[team@pumptechnologyservices.co.uk](mailto:team@pumptechnologyservices.co.uk)

**DRAINMINOR 30 (240V)**  
**(Wastewater Pumping System)**

DrainMinor 30 (240V) Part No. 111  
 (Wastewater Pumping System.)

**General Description:**

DrainMinor 30 (240V) features a heavy-duty tank and submersible pump for automatically pumping wastewater from kitchens, teapoints, etc.

Dimensions mm

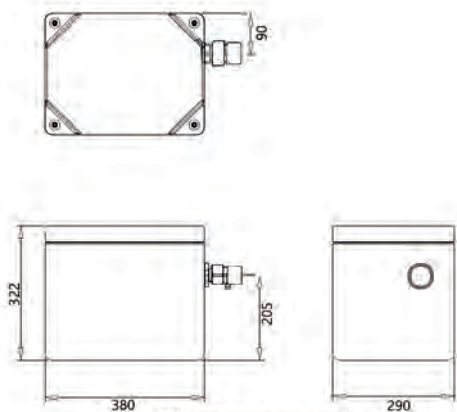
**Tank:**

Manufactured from recyclable polyethylene and fully rigged with internal pipe work and non-return valve. The lid is held in place with easy-to-remove hand screws and sits on a custom moulded, fitted rubber seal.

**Tank Volume: 35.5 litres**

Total Approximate Usable Volume - 23.7 litres

**Tank Inlets:**

To suit site layout, all inverts should be brought into the side of the tank by drilling a hole and using an appropriate tank connector. Minimum invert height 110 mm.

**Good for the Environment:**

**DrainMinor tanks are made from Recyclable Polyethylene.**

Recycling polyethylene is highly cost effective and therefore successful. It is greener than incineration, far more eco-friendly than landfill disposal and easier to use when manufacturing products such as toys, recycling bins, envelopes and much more.

**Tank Outlet:**

Fitted 1¼" BSP male thread discharge outlet (NRV supplied female thread)

**Tank Venting:**

The tank is fitted with its own vent.

**Pump Technology Ltd. - 0118 9821 555 - [www.pumptechnology.co.uk](http://www.pumptechnology.co.uk)**

# PUMP<sup>®</sup> DATA SHEET DRAINMINOR 30 (240V) (Wastewater Pumping System)

TECHNOLOGY LTD

## Pump:

- Cooling jacket for motor housing
- Flushing device activatable and deactivatable
- Variable discharge branch with closable ventilation
- Run dry protection
- EIP Technology
- Moisture sealed cable inlet
- Fluid temperature 35 °C, temporarily 60 °C (10 min.)



## Description:

The heavy duty centrifugal submersible drainage pump U3 KS is suitable for dealing with wastewater and capable of handling soft solids up to 10mm in particle size.

## Dimensions/switching points U3 (mm)

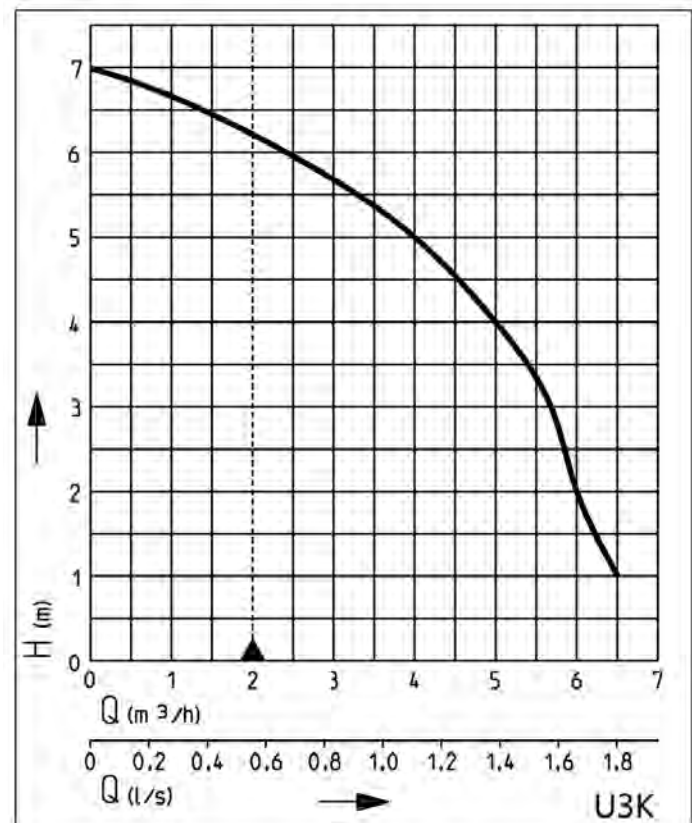
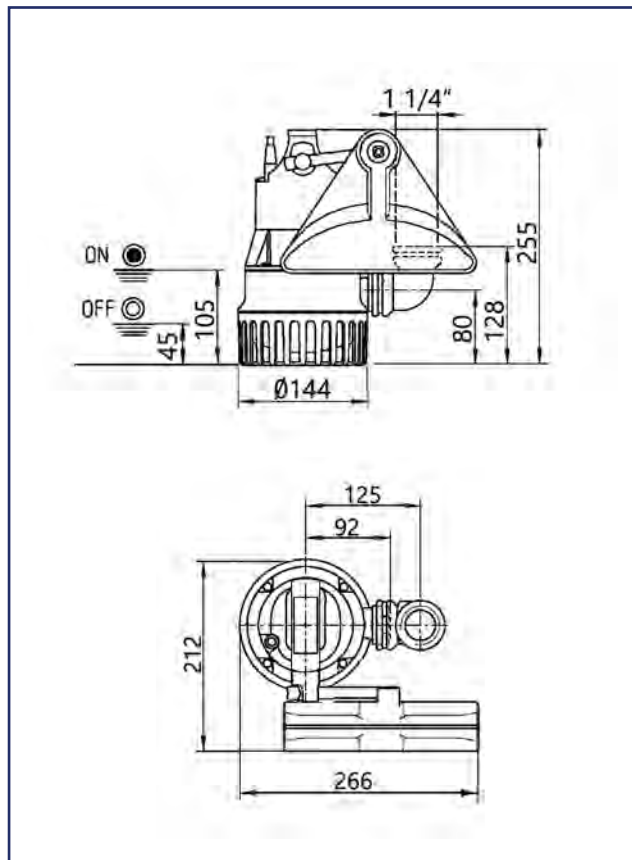

Pump Technology Ltd. - 0118 9821 555 - [www.pumptechnology.co.uk](http://www.pumptechnology.co.uk)

Official Distributor and Stockist Authorised by Jung Pumpen GmbH



2 of 3

# **PUMP**<sup>®</sup> DATA SHEET **DRAINMINOR 30 (240V)** (Wastewater Pumping System)

TECHNOLOGY LTD

**Scope of Supply**

Pump ready for connection acc. to EN 12050 with 90°, 1¼" female connection elbow, 4m cable and automatic level float switch.

**Mechanical Data**

Pump	Vertical single stage	Run dry protection	Yes
Free Passage	10 mm	Shaft	Stainless Steel
Bearing	Ball bearing, grease-lubricated	Impeller	Vortex impeller, GFK
Seal on motor side	Rotary shaft seal	Motor housing	Stainless Steel
Oil chamber	Yes	Pump housing	GRP
Seal on medium side	2-fold rotary shaft seal	Submersible	Yes
		Pressure outlet	1¼"

**Electrical Data**

Voltage	1/N/PE-230V	Insulation class	F
Motor rating P1	0.32kW	Winding thermostat	Yes
Motor rating P2	0.2kW	Motor protection	Integrated
Current	1.4A	Plug	Safety
Type of enclosure	IP 68		

**U3**

Type	Code No.	Power line	Wires	Weight
<b>With built-in level control</b>				
U3 KS, 4m cable	<b>JP50000</b>	4m H07RN-F	3G1,0	5.5kg

**Notes:**

- This unit is for wastewater only
- Ensure the location of the DrainMinor enables the lid to be easily removed for regular inspection and maintenance
- If the discharge pipework connection to a soil stack, manhole etc. is below the discharge outlet of the tank, an anti-syphon unit must be fitted at the highest point of the discharge pipework
- Warranty: The DrainMinor 30 (240V) comes complete with a one year warranty.

**Pump Technology Ltd. - 0118 9821 555 - [www.pumptechnology.co.uk](http://www.pumptechnology.co.uk)**

Official Distributor and Stockist Authorised by Jung Pumpen GmbH



3 of 3

Pump Technology Ltd. reserves the right to change the specification without prior notice.



**DRAINMINOR 30 SL (240V)**  
**(Wastewater Pumping System)**

DrainMinor 30 SL Part No 113  
 (Wastewater Pumping System. Ideal for  
 wastewater containing mildly corrosive chemicals.  
 20 parts per million concentration)

**General Description:**

DrainMinor 30 SL features a heavy-duty tank and submersible pump for automatically pumping wastewater. This small pump features a shaft mechanical seal rather than lip seals, therefore it is suitable for applications like - Laboratories, vets, dentists, hairdresser, janitor sinks and coffee shops where excess coffee granules and milk skin is being washed down a sink.

Dimensions mm

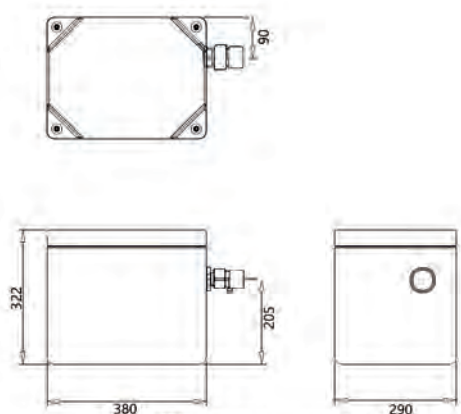
**Tank:**

Manufactured from recyclable polyethylene and fully rigged with internal pipe work and non-return valve. The lid is held in place with easy-to-remove hand screws and sits on a custom moulded, fitted rubber seal.

**Tank Volume: 35.5 litres**

Total Approximate Usable Volume - 23.7 litres

**Tank Inlets:**

To suit site layout, all inverts should be brought into the side of the tank by drilling a hole and using an appropriate tank connector. Minimum invert height 110 mm.

**Good for the Environment:**

**DrainMinor tanks are made from Recyclable Polyethylene.**

Recycling polyethylene is highly cost effective and therefore successful. It is greener than incineration, far more eco-friendly than landfill disposal and easier to use when manufacturing products such as toys, recycling bins, envelopes and much more.

**Tank Outlet:**

Fitted 1¼" BSP male thread discharge outlet (NRV supplied female thread)

**Tank Venting:**

The tank is fitted with its own vent.

**Pump Technology Ltd. - 0118 9821 555 - [www.pumptechnology.co.uk](http://www.pumptechnology.co.uk)**

# PUMP<sup>®</sup> DATA SHEET DRAINMINOR 30 SL (240V) (Wastewater Pumping System)

TECHNOLOGY LTD

## Pump:

- For saline solutions up to 15 % salinity
- Cooling jacket for motor housing
- Low level pumping by detachable strainer base
- Flushing device activatable and deactivatable
- Variable discharge branch with closable ventilation
- Run dry protection
- EIP Technology
- SiC mechanical seal
- Moisture sealed cable inlet



## Description:

The heavy duty centrifugal submersible drainage pump U3K SPEZIAL is suitable for dealing with wastewater and capable of handling soft solids up to 10mm in particle size.

The U3K SPEZIAL is a variant of the U3k (with Mechanical shaft seal) and designed to pump wastewater containing mildly corrosive chemicals (20 parts per million concentration)

## Dimensions/switching points U3 KS (mm)

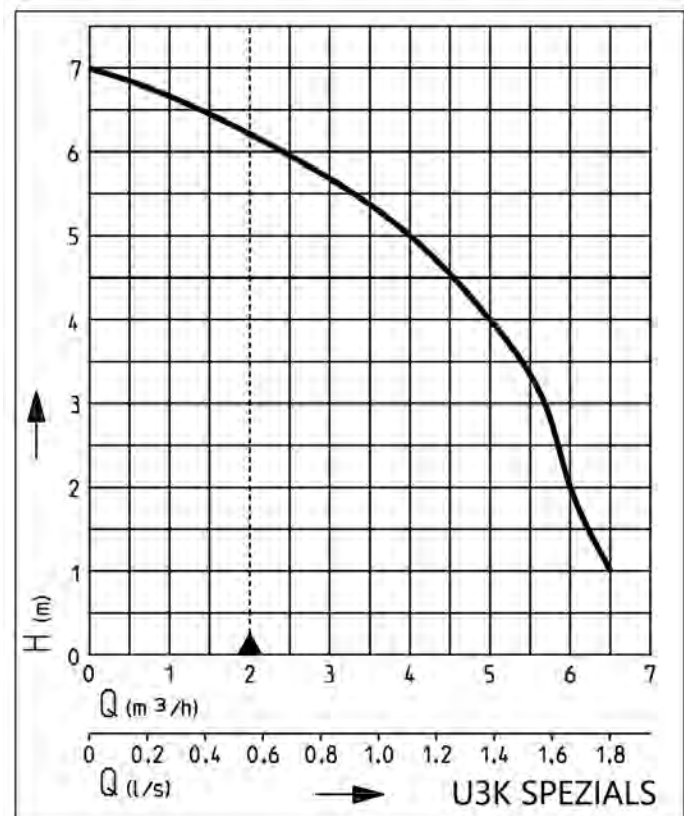
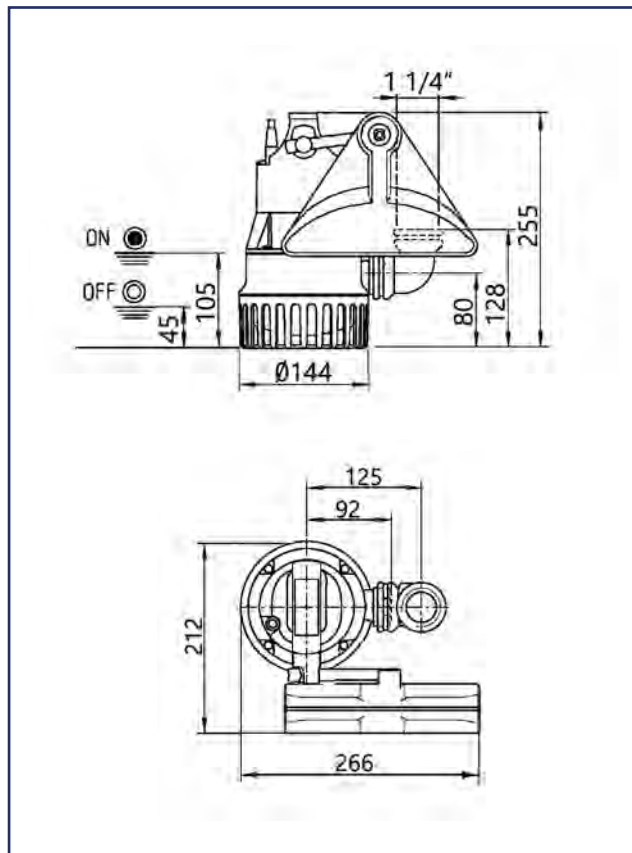

Pump Technology Ltd. - 0118 9821 555 - [www.pumptechnology.co.uk](http://www.pumptechnology.co.uk)

Official Distributor and Stockist Authorised by Jung Pumpen GmbH



2 of 3

# **PUMP**<sup>®</sup> DATA SHEET **DRAINMINOR 30 SL (240V)** (Wastewater Pumping System)

**TECHNOLOGY LTD**

**Scope of Supply**

Pump ready for connection acc. to EN 12050 with 90°, 1¼" female connection elbow, 4m cable with automatic level float switch.

**Mechanical Data**

Pump	Vertical single stage	Run dry protection	Yes
Free Passage	10 mm	Shaft	Stainless Steel
Bearing	Ball bearing, grease-lubricated	Impeller	Vortex impeller, GFK
Seal on motor side	Rotary shaft seal	Motor housing	Stainless Steel
Oil chamber	Yes	Pump housing	GRP
Seal on medium side	SiC mechanical seal	Submersible	Yes
		Pressure outlet	1¼"

**Electrical Data**

Voltage	1/N/PE-230V	Type of enclosure	IP 68
Motor rating P1	0.32kW	Insulation class	B
Motor rating P2	0.2kW	Winding thermostat	Yes
Current	1.4A	Motor protection	Integrated
Type of enclosure	3G1,0	Plug	Safety

**U3 SPEZIAL**

Type	Code No.	Power line	Weight
<b>With built-in level control</b>			
U3 KS spezial, 4m cable	<b>JP50005</b>	4m H07RN-F	3.7kg

**Notes:**

- This unit is for wastewater only
- Ensure the location of the DrainMinor enables the lid to be easily removed for regular inspection and maintenance
- If the discharge pipework connection to a soil stack, manhole etc. is below the discharge outlet of the tank, an anti-syphon unit must be fitted at the highest point of the discharge pipework
- Warranty: The DrainMinor 30 SL (240V) comes complete with a one year warranty.

**Pump Technology Ltd. - 0118 9821 555 - [www.pumptechnology.co.uk](http://www.pumptechnology.co.uk)**

Official Distributor and Stockist Authorised by Jung Pumpen GmbH



3 of 3

Pump Technology Ltd. reserves the right to change the specification without prior notice.



**DRAINMINOR C (240V)**  
**(Combi Oven Pump)**



DRAINMINOR C (240V) (Combi Oven Pump)  
 Part No. 113 C These units have been designed to pump hot wastewater from single or multiple combination ovens. A sink or basin can also be connected.

Key features: Low-level inlet (70mm base to centreline), submersible pump with rigid external float arm, low level float and mechanical shaft seal for reliable operation and long life.

The pump will handle hot water up to 60°C, or even higher temperatures for short periods and can deal with up to 10 mm solids.

**Electrical Data**

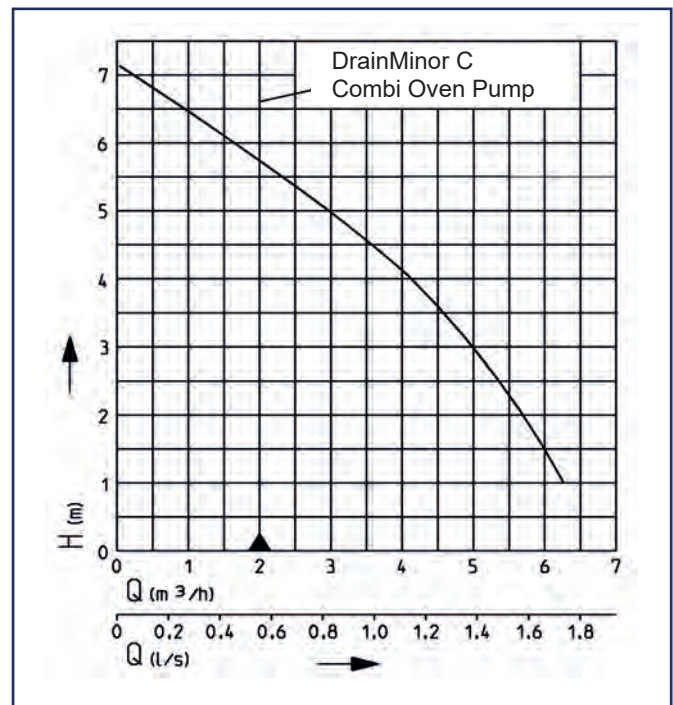
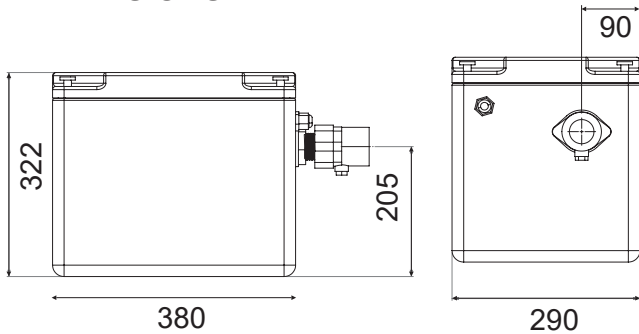
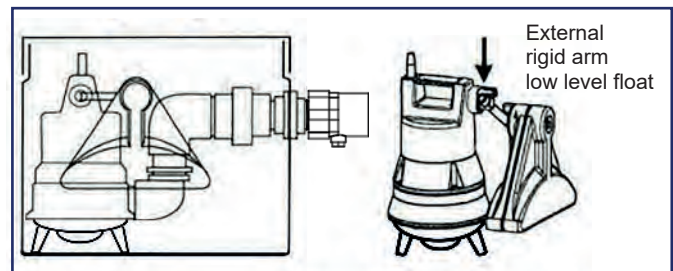
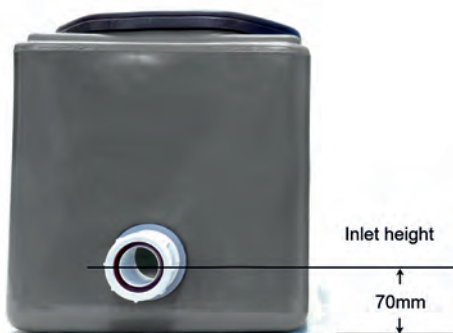
Pump	Current Type	Voltage Volts	Motor Power		R.P.M. Min -1	F.L.C. Amp	Motor Protection	Plug
			P1	P2				
SL30	1 Phase	230	0.32	0.20	2720	1.4	Incorporated	Safety

**DIMENSIONS - mm**

**LOW-LEVEL INLET HEIGHT**

The **DRAINMINOR C** comes complete with a one year warranty.

**DRAINMINOR C (Combi Oven Pump)**

**GOOD FOR THE ENVIRONMENT**
**DrainMinor tanks are made from Recyclable Polyethylene.**

Recycling polyethylene is highly cost effective and therefore successful. It is greener than incineration, far more eco-friendly than landfill disposal and easier to use when manufacturing products such as toys, recycling bins, envelopes and much more.

**Tank Volume: 35.5 litres**

Total Approximate Usable Volume - 23.7 litres

**DrainMinor C:** This consists of a durable tank manufactured from polyethylene laminate.

**Vent:** An integrated, activated charcoal filter is built into the lid of the unit.

**Quantity:** Rigid Polyethylene tank with encapsulated seal and easy-to-remove lid. The tank is recyclable.

**Inverts:** Single or multiple inverts to be made to the tank using tank connectors.

**Outlets:** The tank has a 1¼" BSP discharge outlet.

**Pump Type SL30**

Vertical, single-stage, submersible, max. Soft solids 10 mm. Volute casing with 1¼" (male) radial pressure branch.

**Bearings**

Common shaft for pump and motor, mounted in ball bearings and grease lubricated for life.

**Seal**

Shaft sealing by means of silicon carbide mechanical seal, oil chamber and inboard shaft sealing ring, safe to run dry for short periods.

**Motor**

Submersible motor, type of enclosure IP 68, insulation class B, starting via plug or automatic circuit. Completely water tight cable entry.

**Materials**

Motor housing in high-grade steel, volute casing, impeller and control head in plastic (GRP), shaft in stainless steel, rubber insulated flexible cable.

**Note:**

For continuously rated hot wastewater pumping up to 90°C please see DrainMajor 730HES.

**DRAINMINOR S (240V) (Shower Tray Drain Pump)**



DRAINMINOR S (240V) (Shower Tray Drain Pump)  
 Part No 113S These units have been designed to pump hot wastewater from one or more shower drain trays. A sink or basin can also be connected.

Key features: Low-level inlet (70 mm base to centre line) submersible pump with rigid external float arm, low level float and mechanical shaft seal for reliable operation and long life.

The pump will handle hot water up to 60°C, or even higher temperatures for short periods and can deal with shampoos and gels etc.

**Electrical Data**

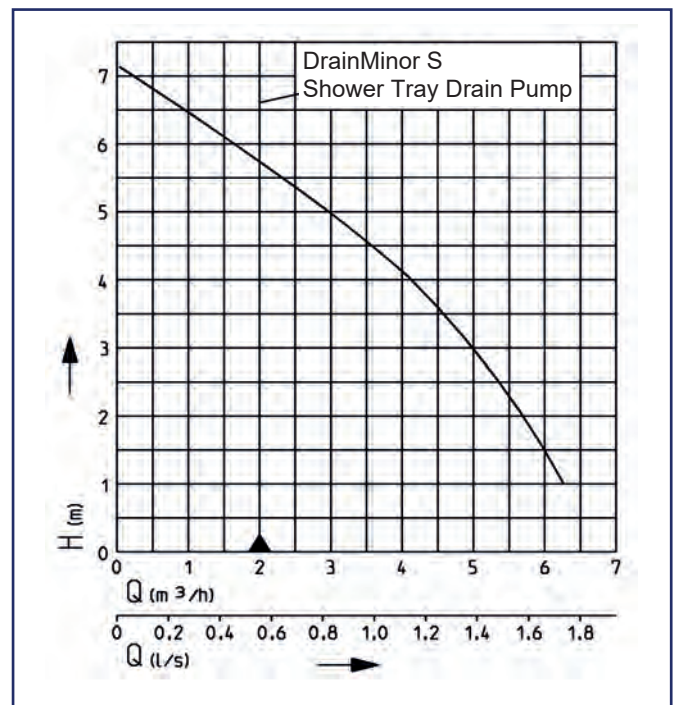
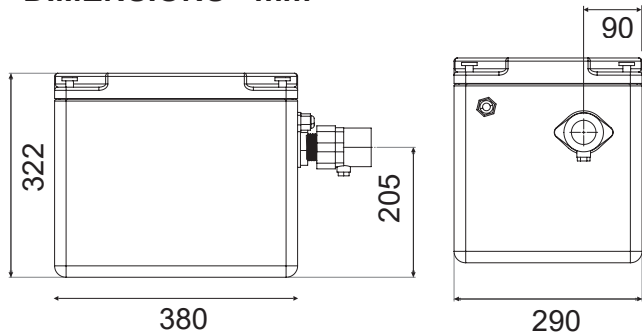
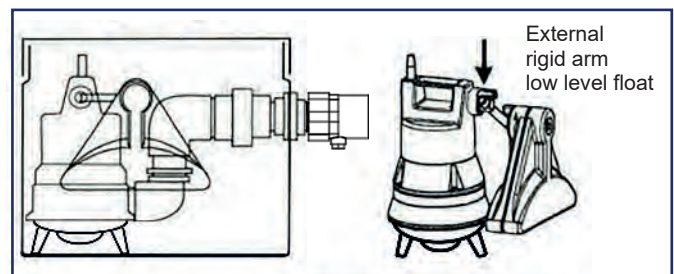
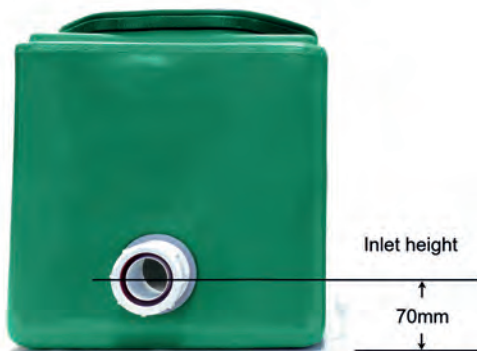
Pump	Current Type	Voltage Volts	Motor Power		R.P.M. Min -1	F.L.C. Amp	Motor Protection	Plug
			P1	P2				
SL30	1 Phase	230	0.32	0.20	2720	1.4	Incorporated	Safety

**DIMENSIONS - mm**

**LOW-LEVEL INLET HEIGHT**

The **DRAINMINOR S** comes complete with a one year warranty.

# **PUMP**<sup>®</sup> DATA SHEET **DRAINMINOR S (Shower Tray Drain Pump)**

TECHNOLOGY LTD



## GOOD FOR THE ENVIRONMENT

### **DrainMinor tanks are made from Recyclable Polyethylene.**

Recycling polyethylene is highly cost effective and therefore successful. It is greener than incineration, far more eco-friendly than landfill disposal and easier to use when manufacturing products such as toys, recycling bins, envelopes and much more.

### **Tank Volume: 35.5 litres**

Total Approximate Usable Volume - 23.7 litres

**DrainMinor S:** This consists of a durable tank manufactured from polyethylene laminate.

**Vent:** An integrated, activated charcoal filter is built into the lid of the unit.

**Quantity:** Rigid Polyethylene tank with encapsulated seal and easy-to-remove lid. The tank is recyclable.

**Inverts:** Single or multiple inverts to be made to the tank using tank connectors.

**Outlets:** The tank has a 1¼" BSP discharge outlet.

### **Pump Type SL30**

Vertical, single-stage, submersible. Volute casing with 1¼" (male) radial pressure branch.

### **Bearings**

Common shaft for pump and motor, mounted in ball bearings and grease lubricated for life.

### **Seal**

Shaft sealing by means of silicon carbide mechanical seal, oil chamber and inboard shaft sealing ring, safe to run dry for short periods.

### **Motor**

Submersible motor, type of enclosure IP 68, insulation class B, starting via plug or automatic circuit. Completely water tight cable entry.

### **Materials**

Motor housing in high-grade steel, volute casing, impeller and control head in plastic (GRP), shaft in stainless steel, rubber insulated flexible cable.